



IP20

ONTEC G

Deckenaufbauleuchte
Ceiling spotlight fixture
Luminaire ponctuel de plafond



220-240V~
50/60Hz

Tc (K)
5000

IP
20

(mm³)
5x(1-1,5)

(°C)
10-40°C



ONTEC G

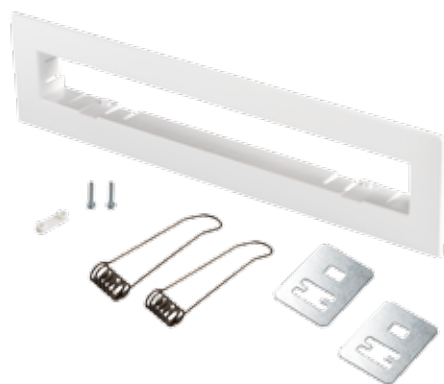

ZEST. MONT.P/T ONTEC G

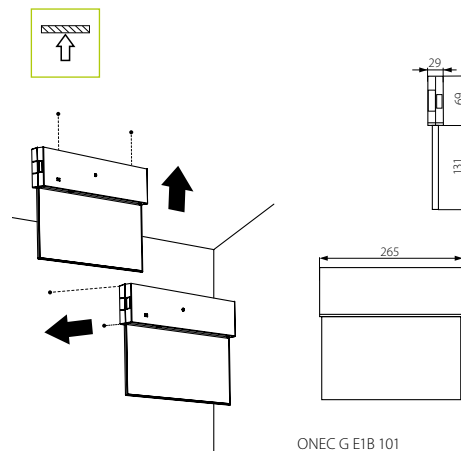

ONTEC G E1B 101

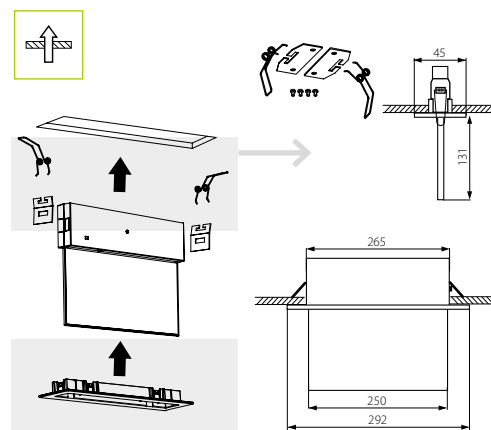

ZEST. MONT.P/T ONTEC G



Kanlux



Kanlux



AT

ONTEC G E1B 101 M ST/W	27394	1	1	≥300	✓	+	ZEST.MONT.P/T ONTEC G	27051	✓	
ONTEC G E1B 301 M ST/W	27395	1	3	≥300	✓	+	ZEST.MONT.P/T ONTEC G	27051	✓	
ONTEC G E1B 101 M AT/W	27750	1	1	≥300	✓	+	ZEST.MONT.P/T ONTEC G	27051	✓	✓
ONTEC G E1B 301 M AT/W	25435	1	3	≥300	✓	+	ZEST.MONT.P/T ONTEC G	27051	✓	✓

DE

Aluminium
Gehäuse: gebürstetes Aluminium

Ladezeit des Akkus 24h / In den Leuchten können Evakuierungspiktogramme der Reihe PICTO verwendet werden / Die Leuchte verfügt über eine elektronische Sicherung gegen Entladung des Akkus / Zweifunktion-Notleuchte, arbeitet im Netz- und Notfallbetrieb, / Arbeitszeit im Notbetrieb 1, 2 oder 3 Stunden

- Arbeitszeit im Notbetrieb

27051 Montagesatz P/T

AT-Autotest
ST - manueller Test oder mit Hilfe eines ferngesteuerten Testgeräts.

EN

aluminium
casing: brushed aluminium

battery charging time 24 h / light fixtures can be provided with PICTO emergency exit signs / the light fixture is provided with electronic safety features for protection against battery discharge / dual-purpose emergency light fixture, operates in mains supply and emergency modes, working time in emergency mode 1, 2 or 3 hours

- working time in emergency mode

27051 F/M installation set

AT-Autotest
ST - manual test or with the use of a remote-controlled testing device.

FR

aluminium
boîtier: aluminium brossé

temps de charge de l'accumulateur 24h/les signes d'évacuation de la série PICTO peuvent être utilisés dans les luminaires/ le luminaire est équipé d'une protection électronique contre la décharge de l'accumulateur/ luminaire d'urgence à fonction double, fonctionne en mode de réseau et d'urgence/temps de fonctionnement en mode de secours est de 1, 2 ou 3 heures

- temps de fonctionnement en mode de secours est

27051 Kit de montage P/T

AT-Autotest
ST - test manuel ou à l'aide d'un appareil de test à distance