

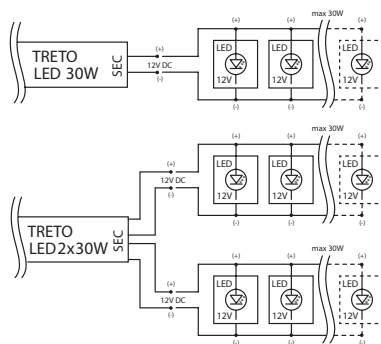

TRETO LED 30W

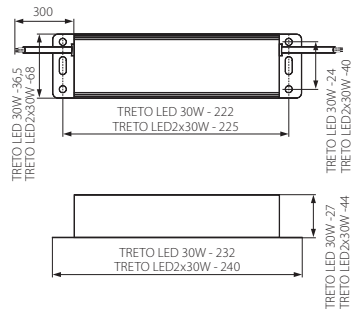

TRETO LED2x30W



- ▶ casing: anodized aluminum
- ▶ Gehäuse: anodisiertes Aluminium

Kanlux			PRI	SEC		
TRETO LED 30W	07800	chrome / chrom	170-230V~; 50/60Hz	DC 2,5A (12V); 0...30W	1/-/50	400
TRETO LED2x30W	07801	chrome / chrom	170-230V~; 50/60Hz	DC 5A (12V); 2 x (0...30W)	1/-/10	1235



voltage stabilisation 12V DC / max allowable temperature of a casing 65°C / built-in short circuit protection and overload protection / built-in system of radio interference reduction and power factor boost
 Spannungstabilisierung 12V Gleichstrom / die maximal zulässige Gehäusetemperatur beträgt 65°C / eingebaut Kurzschlußschutz und Überlastschutz / eingebautes System zur Reduzierung radioelektrischer Störungen und Verbesserung des Leistungsfaktors